

RepRap Morgan arm PSI

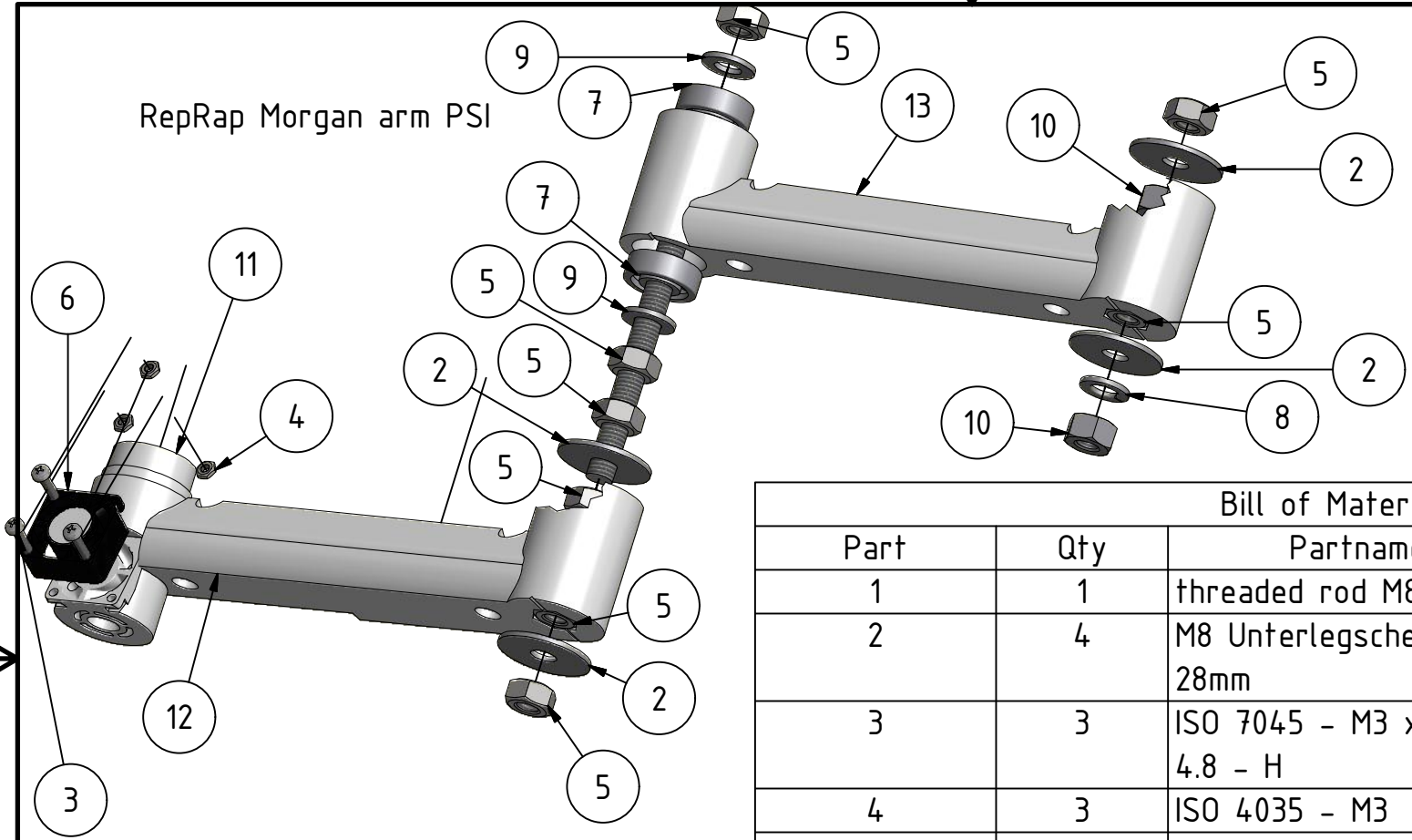

Bill of Materials

Part	Qty	Partname	Description
1	1	threaded rod M8 100mm	
2	4	M8 Unterlegscheibe 28mm	M8 washer
3	3	ISO 7045 - M3 x 12 - 4.8 - H	M3 bolt, 12mm
4	3	ISO 4035 - M3	M3 nut
5	8	ISO 4032 - M8	M8 nut
6	1	Fan Sunon MC25101V2-000U-A99	
7	2	DIN 625 SKF - SKF 608	bearing 608
8	1	DIN 128 - A8	M8 sping washer
9	2	DIN 125 - A 8,4	M8 washer
10	2	ANSI B18.2.4.2M - M8x1,25	M8 nut
11	1	21-Morgan_toolhead_V3	printed part
12	1	18-Morgan_arm_PSI_b	printed part
13	1	17-Morgan_arm_PSI_a	printed part